

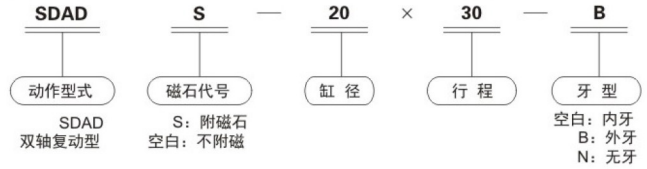

型号表示方法



订货举例

- 欲订购缸径为20mm, 行程为30mm, 附磁石, 活塞杆牙型为内牙型式的双轴复动型超薄气缸, 其正确的订购代码为: SDADS-20×30
- 欲订购缸径为63mm, 行程为35mm, 不附磁石, 活塞杆牙型为无牙型式的双轴复动型超薄气缸, 其正确的订购代码为: SDAD-60×35-N.

符号



外形尺寸图(毫米)

●SDAD、SDADS型

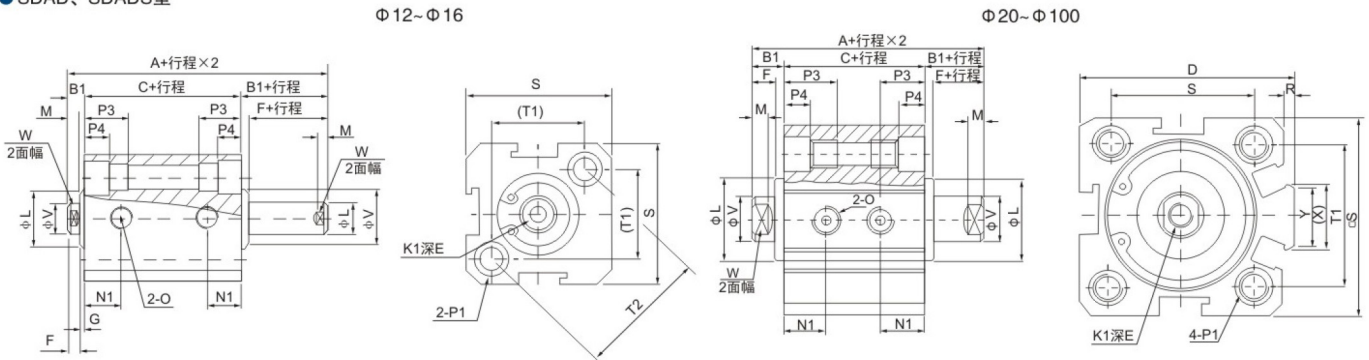

型式 内径\符号	不附磁		附磁		B1	D	行程≤10		行程>10		F	G	K1	L	M	N1	
	A	C	A	C			E		S=5	S>5							
12	27	17	37	27	5	-	6				4	1	M3×0.5	10.2	3	5.5	6.3
16	29.5	18.5	39.5	28.5	5.5	-	6		4	1.5	M3×0.5	11	3	6.5	7.3		
20	30.5	19.5	40.5	29.5	5.5	36	8(行程=5时为6.5)		4	1.5	M4×0.7	13	3	7.5			
25	33	21	43	31	6	42	10(行程=5时为7)		4	2	M5×0.8	17	3	8			
32	38.5	24.5	48.5	34.5	7	50	8	12	4	3	M6×1	22	3	8	9		
40	40	26	50	36	7	58.5	8	12	4	3	M8×1.25	28	3	8	10		
50	46	28	56	38	9	71.5	8	15	5	4	M10×1.5	38	3	8	10.5		
63	50	32	60	42	9	84.5	10	15	5	4	M10×1.5	40	3	9.5	11.8		
80	63	41	73	51	11	104	13	20	6	5	M14×1.5	45	4	11.5	14.5		
100	75	51	85	61	12	124	18	20	7	5	M18×1.5	55	4	16	20.5		

内径\符号	O	P1	P3	P4	R	S	T1	T2	V	W	X	Y
12	M5×0.8	双边: φ6.5牙 M5×0.8通孔: φ4.2	12	4.5	-	25	16.3	23	6	5	-	-
16	M5×0.8	双边: φ6.5牙 M5×0.8通孔: φ4.2	12	4.5	-	29	19.8	28	6	5	-	-
20	M5×0.8	双边: φ6.5牙 M5×0.8通孔: φ4.2	14	4.5	2	34	24	-	8	6	11.3	10
25	M5×0.8	双边: φ8.2牙 M6×1.0通孔: φ4.6	15	5.5	2	40	28	-	10	8	12	10
32	PT1/8	双边: φ8.2牙 M6×1.0通孔: φ4.6	16	5.5	6	44	34	-	12	10	18.3	15
40	PT1/8	双边: φ10牙 M8×1.25通孔: φ6.5	20	7.5	6.5	52	40	-	16	14	21.3	16
50	PT1/4	双边: φ11牙 M8×1.25通孔: φ6.5	25	8.5	9.5	62	48	-	20	17	30	20
63	PT1/4	双边: φ11牙 M8×1.25通孔: φ6.5	25	8.5	9.5	75	60	-	20	17	28.7	20
80	PT3/8	双边: φ14牙 M12×1.75通孔: φ9.2	25	10.5	10	94	74	-	25	22	36	26
100	PT3/8	双边: φ17.5牙 M14×2通孔: φ11.3	30	13	10	114	90	-	32	27	35	26

外牙尺寸 外牙尺寸请参考页