

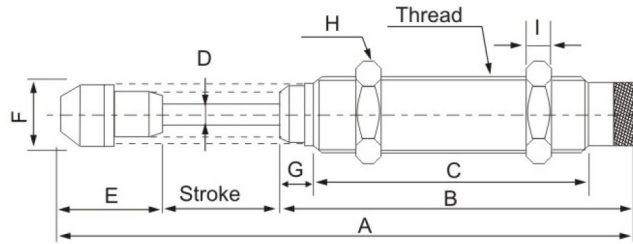

## 外形尺寸图(毫米)

## ● AD2540



## ● AD3625

## ● AD3650

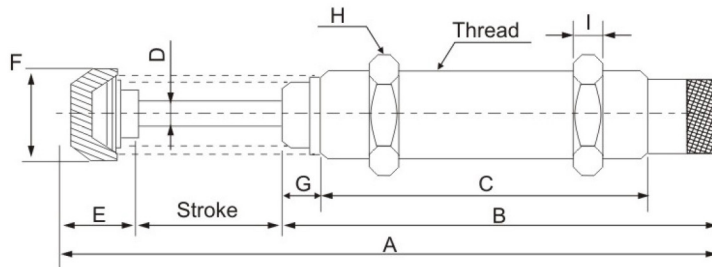

## ● AD4225

## ● AD4250

## ● AD4275

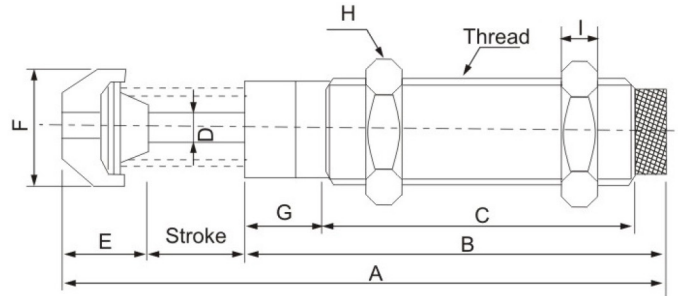

## ● AD64050

## ● AD64100

## ● AD64150

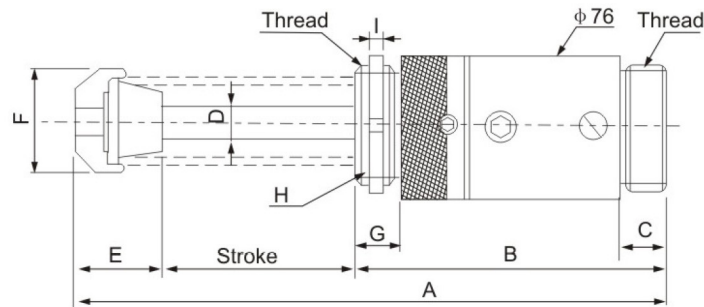

型号	螺纹公称	行程(mm)	A	B	C	D	E	F	G	H	I
AD2540	M25 × 1.5	40	218	132	115	8	35.6	22	9.4	32	10
AD3625	M36 × 1.5	25	186.5	126	96	10	26	35	10	46	15
AD3650	M36 × 1.5	50	247	171	134	10	26	35	17	46	15
AD4225	M42 × 1.5	25	186.9	127.5	88.5	12	33.9	43.7	29	49	15
AD4250	M42 × 1.5	50	246	157.3	118.3	12	38.2	43.7	29	49	15
AD4275	M42 × 1.5	75	301.4	187.8	148.8	12	38.2	43.7	29	49	15
AD-64050	UNF21/2-12	50	247.8	146	26	20	51.8	59	23	76.2	9.4
AD-64100	UNF21/2-12	100	347.8	196	26	20	51.8	59	23	76.2	9.4
AD-64150	UNF21/2-12	150	467.8	256	26	20	51.8	59	23	76.2	9.4

 Execution Element  
 执行元件

 Control Units  
 控制元件

 Air Source Treatment units  
 气源处理元件

 Pneumatic Accessory  
 气动辅助件